

Coati Open Source Spider — Building manual

Version 1.1

<https://coati.pimienta.org/electronics/spider/design>

Contents

| | |
|-------------------------------------|----|
| Assembly tips | 2 |
| Multiplying factors | 2 |
| Spider 1.1 schematics | 3 |
| Spider 1.1 board | 4 |
| Spider parts list 1.1 | 5 |
| Spider building instructions 1.1 | 6 |
| Extension 1.1 schematics | 9 |
| Extension 1.1 board | 10 |
| Extension parts list 1.1 | 11 |
| Extension building instructions 1.1 | 11 |

Assembly tips

Soldering tips

- Before soldering a component, check whether it has to be soldered from the top, from the bottom, or both. Do not solder on one side if it is not needed, except maybe for plugs and other mechanical parts in order to make them stronger.
- To solder a component, solder one of the contact first, then melt this contact and adjust the placement of the component before letting the contact cool down and solidify, and solder the other contacts.
- When soldering electrolytic capacitors, press them well onto the PCB to make sure that they are not stick out of the rest of components.
- Always shutdown the devices that you are assembling before soldering or mounting components.

Integrated circuits pin numbering

Copied from Wikipedia.

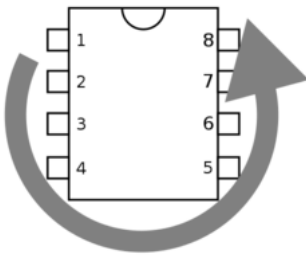

Multiplying factors

Bigger than one

| Symbol | Name | Value | Equivalents | |
|--------|------|------------------------|--------------------------------|---------------------------------|
| k | kilo | $\times 1000$ | | $0.001 \text{ k} = 1$ |
| M | mega | $\times 1000000$ | $1000 \text{ k} = 1 \text{ M}$ | $0.001 \text{ M} = 1 \text{ k}$ |
| G | giga | $\times 1000000000$ | $1000 \text{ M} = 1 \text{ G}$ | $0.001 \text{ G} = 1 \text{ M}$ |
| T | tera | $\times 1000000000000$ | $1000 \text{ G} = 1 \text{ T}$ | $0.001 \text{ T} = 1 \text{ G}$ |

Smaller than one

| Symbol | Name | Value | Equivalents | |
|--------|-------|-------------------------|--------------------------------|---------------------------------|
| m | milli | $\times 0.001$ | $1000 \text{ m} = 1$ | $0.001 \text{ m} = 1 \mu$ |
| μ | micro | $\times 0.000001$ | $1000 \mu = 1 \text{ m}$ | $0.001 \mu = 1 \text{ n}$ |
| n | nano | $\times 0.000000001$ | $1000 \text{ n} = 1 \mu$ | $0.001 \text{ n} = 1 \text{ p}$ |
| p | pico | $\times 0.000000000001$ | $1000 \text{ p} = 1 \text{ n}$ | |

Spider 1.1 schematics

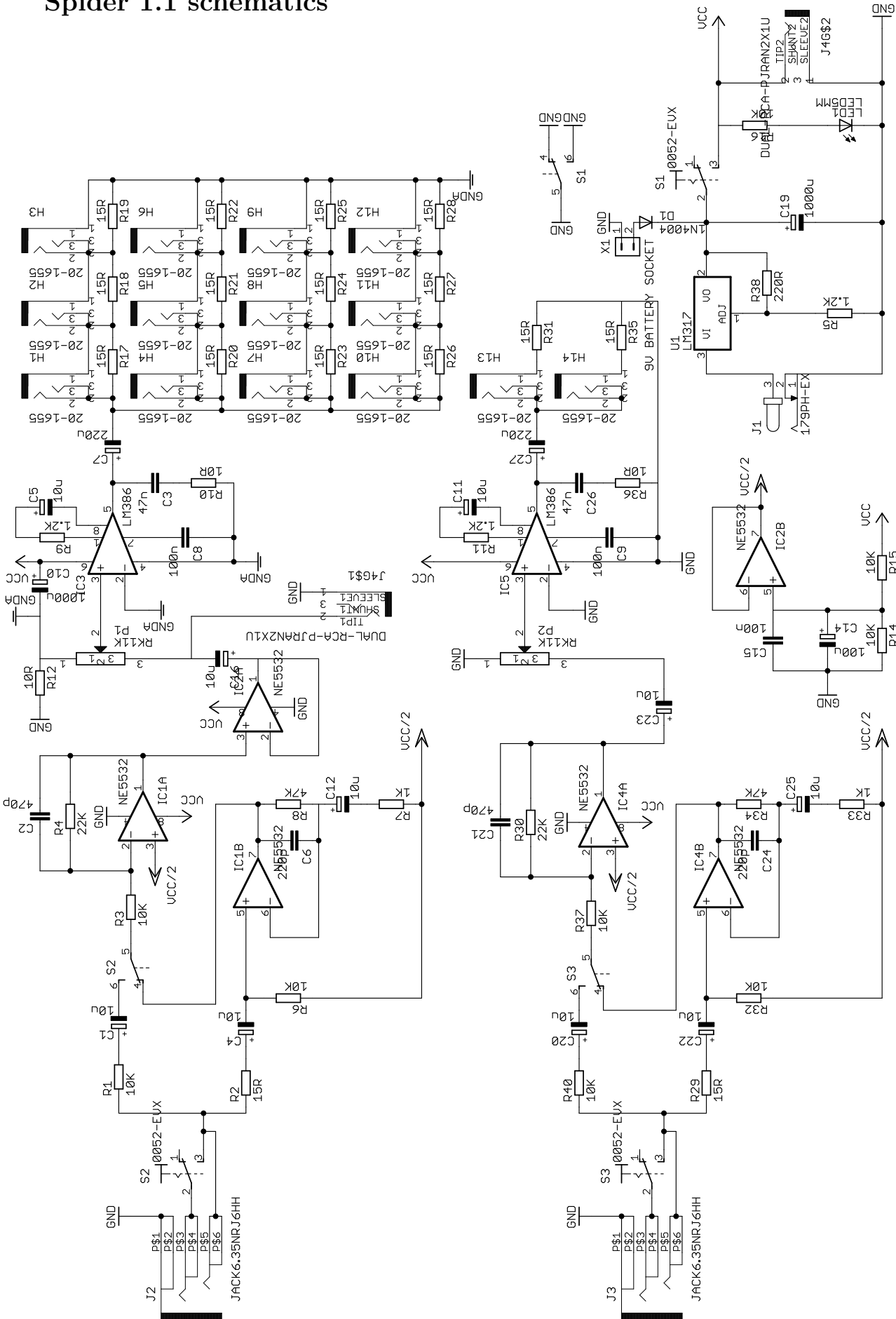

Spider parts list 1.1

| Part | Value | Quantity | Mouser reference |
|--|-------------------------------|----------|---|
| Resistors | | | |
| R10, R12, R36 | 10 Ω | 3 | 291-10-RC |
| R2, R17 to R29, R31, R35 | 15 Ω | 16 | 291-15-RC |
| R38 | 220 Ω | 1 | 291-220-RC |
| R7, R33 | 1 k Ω | 2 | 291-1K-RC |
| R5, R9, R11 | 1.2 k Ω | 3 | 291-1.2K-RC |
| R1, R3, R6, R14, R15, R16, R32, R37, R40 | 10 k Ω | 9 | 291-10K-RC |
| R4, R30 | 22 k Ω | 2 | 291-22K-RC |
| R8, R34 | 47 k Ω | 2 | 291-47K-RC |
| Potentiometers | | | |
| P1, P2 | 10 k Ω log, Alps RK11K | 2 | 688-RK11K1130A07 |
| Knob | Eagle 450-476X or 450-466Xs | 2 | black: Eagle 450-476 grey: Eagle 450-466 |
| Capacitors | | | |
| C6, C24 | 220 pF | 2 | 594-S221K25Y5PN6TK5R |
| C2, C21 | 470 pF | 2 | 594-S471K25Y5PN6TJ5R |
| C3, C26 | 47 nF | 2 | 871-B32529C1473J189 |
| C8, C9, C15 | 100 nF | 3 | 871-B32529C104K189 |
| C1, C4, C5, C11, C12, C16, C20, C22, C23, C25 | 10 μ F | 10 | 140-REA100M1VBK0511P |
| C14 | 100 μ F | 1 | 140-REA101M1ABK0511P |
| C7, C27 | 220 μ F | 2 | 140-REA221M1ABK0611P |
| C10, C19 | 1000 μ F | 2 | 140-REA102M1ABK1012P |
| Integrated circuits | | | |
| IC1, IC2, IC4 | NE5532 | 3 | 595-SA5532PE4 |
| IC3, IC5 | LM386N-3 | 2 | 926-LM386N-3/NOPB |
| U1 | LM317 | 1 | 511-LM317T |
| DIL8 socket | Mill-Max 110-99-308-41-001000 | 5 | 575-199308 |
| Electromechanical parts | | | |
| S1, S2, S3 | Mountain Switch 0052-EVX | 3 | 108-0052-EVX |
| X1 | 3M 961102-5604-AR | 1 | 961102-5604-AR |
| Battery clip | Eagle 123-4016/M-GR | 1 | 123-4016/M-GR |
| Plugs | | | |
| H1 to H14 | TruConnect 20-1655 | 14 | Rapid: 20-1655 |
| J1 | Kobiconn 179PH-EX | 1 | 163-179PH-EX |
| J2, J3 | Rean NRJ6HH | 2 | 550-25301 |
| J4 | Switchcraft PJRAN2X1U | 1 | 502-PJRAN2X1U02X |
| Misc | | | |
| LED1 | Cree C535A-WJN-CS0V0151 | 1 | 941-C535AWJNCS0V0151 |

| Part | Value | Quantity | Mouser reference |
|-----------------|-------------------------|----------|--|
| D1 | 1N4004 | 1 | 512-1N4004 |
| Hardware | | | |
| Enclosure | Hammond 1599EBAT | 1 | black: 546-1599EBKBAT grey: 546-1599EGYBAT economic: 546-1599ESGYBAT |
| Heat sink | Aavid Thermalloy 6237BG | 1 | 532-6237B |
| Spacer | Raf M2110-3005-AL | 6 | 761-M2110-3005-AL |
| Bolt | M3 | 6 | |

Spider building instructions 1.1

Introduction

Make sure you read our assembly tips.

The components marked with a + have a polarity.

To mount them the right way, look for hints either:

- on the screenprinting on the PCB itself
- in the Eagle file of the board
- in the datasheet of the component linked from the parts list

PCB drill sizes

- \varnothing 0.8: all drills unless documented otherwise.
- \varnothing 1.0: leads of the potentiometers P1 and P2, battery connector X1, and diode D1.
- \varnothing 1.2: leads of the LM317 U1, and interruptors S1, S2, and S3.
- \varnothing 1.5: leads of the input jacks J2 and J3, central lead of the headphone plugs H1 to H14.
- \varnothing 2.0: plastic anchors of the input jacks J2 and J3.
- \varnothing 2.5: small leads of the power plug J1, anchors of the potentiometers P1 and P2, lateral leads of the headphone plugs H1 to H14, and leads of the extension plug J4.
- \varnothing 3.0: big lead of the power plug J1 and spacers.

Enclosure drills

Panel

0. Print the layer “Screenprint” of the board design on the side of the enclosure which has the battery lid.
1. Drill all the holes first at \varnothing 2 and then at \varnothing 5.
2. Drill the holes of the potentiometers and headphone plugs at \varnothing 7.

Sides

0. Close the enclosure with its screws. Drill first at \varnothing 2 and then at \varnothing 5 to be able to adjust the placement:
 - Power plug J1: \varnothing 7. Center on the junction between the two parts of the enclosure.
 - Input jacks J2 and J3: \varnothing 9. Center on the junction between the two parts of the enclosure.
 - Extension plug J4: \varnothing 10. Center 1.0 mm above the junction of the two parts of the enclosure.

Preparation

0. Solder the 5 DIL8 sockets+. The socket pins which have to be soldered on top have a longer shape to ease soldering.
1. Mount the spacers: the spacer itself goes on the bottom of the PCB, the washer, and then the bolt go on top of the PCB.
2. Test for short-circuits between the pins of the sockets.

Power supply

0. Solder J1 both on top and on the bottom of the PCB to make it stronger.
1. Plug the heat sink on the LM317 U1: the flat part of the heat sink touches the metal plate of the LM317. Mount the LM317 on the bottom of the PCB, and bend the wider part of the LM317 leads to fit the heat sink in its correct position: the flat part of the heat sink touches the bottom of the PCB. Solder U1. Beware: it is all-right for the heat sink to touch the central lead of the LM317 but not the other ones. Then separate a bit the LM317 from the PCB to make sure it doesn't touch the other components.
2. Solder J1, U1+, R5, R38, C19+, X1+, S1, and R16. C19+ must be well pressed onto the PCB.
3. Solder LED1+ so its base is 11 mm above the PCB. The flat side of the LED must be on the side of the switch.
4. Solder D1+. The white marker on the diode must be the side of the switch.
5. Plug the DC transformer and measure 8 V between the lateral lead of J1 (GND) and the central lead of the LM317 (VCC).
6. Unplug the DC transformer and connect a 9 V battery. Verify that the LED lights on with the battery only.

Virtual ground

0. Solder R14, R15, C14+, and C15.
1. Mount IC2+.
2. Measure 8 V between pin 8 of IC2 (VCC) and GND.
3. Measure 4 V between pin 5 of IC2 (VCC/2) and GND.
4. Measure 4 V between pin 6 of IC2 (VCC/2) and GND.

Floor line amplification

0. Solder J3, S3, R40, C20+, R37, R30, C21, and C23+.
1. Mount IC4+.
2. With an oscilloscope, visualize the signal of a line input on pin 1 of IC4.
3. To feed a continuous sine signal into the line input you can run the following command in Linux:
speaker-test -t sine

Floor power amplifier

0. Solder P2, C9, C26, R36, C27+, R11, C11+, R31, R35, H13, and H14. P2 must be well pressed onto the PCB.
1. Mount IC5+.

R11 sets the gain of the LM386. As explained in the datasheet, without this resistor, the gain is set to 20, with a resistor of 1.2 k Ω to 50, and with a shunt to 200. Let's put a 1.2 k Ω resistor by default.

0. Listen to a line input in the 2 headphone plugs.

Floor microphone amplification

0. Solder R29, R32, C22+, C24, R34, C25+, and R33.
1. Listen to a microphone input in the headphone plugs.

Interpretation line amplification

0. Solder J2, S2, R1, C1+, R3, R4, C2, and C16+.
1. Mount IC1+.
2. With an oscilloscope, visualize the signal of a line input on pin 1 of IC1.

Interpretation power amplifier

0. Solder R12, P1, C8, C3, R10, C7+, C10+, R9, C5+, R28, H12, R27, H11, R26, and H10. C10 and P1 must be well pressed onto the PCB.
1. Mount IC3+.

R9 sets the gain of the LM386. As explained in the datasheet, without this resistor, the gain is set to 20, with a resistor of 1.2 k Ω to 50, and with a shunt to 200. Let's put a 1.2 k Ω resistor by default.

0. Solder C10 on the bottom of the PCB.
1. Listen to a line input in the 3 headphone plugs.

Interpretation microphone amplification

0. Solder R2, C4+, R6, C6, R8, C12+, and R7.
1. Listen to a microphone input in the headphone plugs.

Interpretation headphone plugs

0. Solder R20, R21, R22, R23, R24, R25, R26, R27, R28, H4, H5, H6, H7, H8, H9, H10, H11, and H12.
1. Listen to a microphone input in the 12 headphone plugs.

Extension plug

0. Solder J4.
1. Measure 8 V between the pin of the red RCA plug and GND.
2. With an oscilloscope, visualize an audio signal on the pin of the black RCA plug.

Extension 1.1 schematics

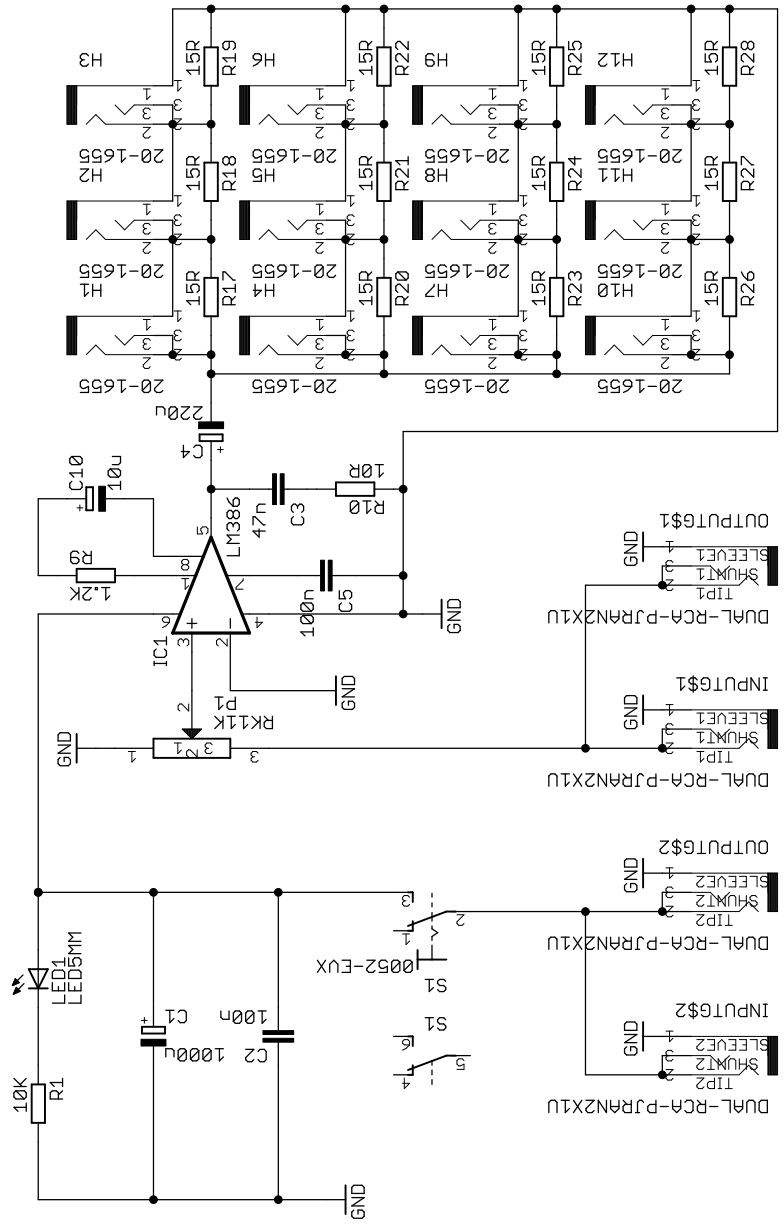

Extension parts list 1.1

| Part | Value | Quantity | Mouser reference |
|-----------------|-------------------------------|----------|---|
| R10 | 10 Ω | 1 | 291-10-RC |
| R17 to R28 | 15 Ω | 12 | 291-33-RC |
| R9 | 1.2 k Ω | 1 | 291-1.2K-RC |
| R1 | 10 k Ω | 1 | 291-10K-RC |
| P1 | 10 k Ω log, Alps RK11K | 1 | 688-RK11K1130A07 |
| C3 | 47 nF | 1 | 871-B32529C1473J189 |
| C2, C5 | 100 nF | 2 | 871-B32529C104K189 |
| C10 | 10 μ F | 1 | 140-REA100M1VBK0511P |
| C4 | 220 μ F | 1 | 140-REA221M1ABK0611P |
| C1 | 1000 μ F | 1 | 140-REA102M1ABK1012P |
| H1 to H12 | TruConnect 20-1655 | 12 | Rapid: 20-1655 |
| IC3 | LM386N-3 | 1 | 926-LM386N-3/NOPB |
| DIL8 socket | Mill-Max 110-99-308-41-001000 | 1 | 575-199308 |
| LED1 | Cree C535A-WJN-CS0V0151 | 1 | 941-C535AWJNCS0V0151 |
| INPUT, OUTPUT | Switchcraft PJRAN2X1U | 2 | 502-PJRAN2X1U02X |
| S1 | Mountain Switch 0052-EVX | 1 | 108-0052-EVX |
| Hardware | | | |
| Enclosure | Hammond 1599B | 1 | black: 546-1599B-BK grey: 546-1599BS-GY economic: 546-1599BS-GY |

Extension building instructions 1.1

Introduction

Make sure you read our assembly tips.

The components marked with a + have a polarity.

To mount them the right way, look for hints either:

- on the screenprinting on the PCB itself
- in the Eagle file of the board
- in the datasheet of the component linked from the parts list

PCB drill sizes

- \varnothing 0.8: all drills unless documented otherwise.
- \varnothing 1.0: leads of the potentiometer P1.
- \varnothing 1.2: leads of the interruptor S1.
- \varnothing 1.5: central lead of the headphone plugs H1 to H12.
- \varnothing 2.5: anchors of the potentiometer P1, lateral leads of the headphone plugs H1 to H12, and leads of the RCA plugs INPUT and OUTPUT.

Enclosure drills

Panel

0. Print the layer “Screenprint” of the board design on the side of the enclosure which has apparent screw holes.
1. Drill all the holes first at $\varnothing 2$ and then at $\varnothing 5$.
2. Drill the holes of the potentiometers and headphones plugs at $\varnothing 7$.

Sides

0. Close the enclosure with its screws. Drill first at $\varnothing 2$ and then at $\varnothing 5$ to be able to adjust the placement:
 - RCA plugs INPUT and OUTPUT: $\varnothing 10$. Center 1.0 mm above the junction of the two parts of the enclosure.

Preparation

0. Solder the DIL8 socket+ of the LM386.
1. Test for short-circuits between the pins of the socket.

Power supply

0. Solder INPUT, OUTPUT, S1, C2, C1+, and R1.
1. Solder LED1+ so its base is 11 mm above the PCB. The flat side of the LED must be on the side of the switch.
2. Mount IC3+.
3. Plug the extension to a Spider, and verify that the LED lights on.
4. Measure 8 V between the shields of the RCA plugs and pin 6 of the LM386 (VCC).

Power amplifier

0. Solder P1, R9, C10+, C5, C3, R10, C4+, R26, R27, R28, H10, H11, and H12. P1 must be well pressed onto the PCB.

R9 sets the gain of the LM386. As explained in the datasheet, without this resistor, the gain is set to 20, with a resistor of 1.2 k Ω to 50, and with a shunt to 200. Let's put a 1.2 k Ω resistor by default.

0. Plug the extension to a Spider, and listen to the signal from the Spider in the 3 headphone plugs.

Interpretation

0. Solder R17, R18, R19, R20, R21, R22, R23, R24, R25, H1, H2, H3, H4, H5, H6, H7, H8, and H9.
1. Plug the extension to a Spider, and listen to the output of the Spider in all the 12 headphone plugs.